

SONIQ

65" UltraHD Chromecast built-in TV
Instruction Manual

N65UV17A-AU

 Chromecast built-in

Safety Instruction

Important Safety Instructions

WARNING

- TO PREVENT FIRE OR SHOCK HAZARD. DO NOT USE AN EXTENSION CORD.
- TO PREVENT FIRE OR SHOCK HAZARD, DO NOT EXPOSE THIS APPLIANCE TO RAIN OR MOISTURE.
- TO PREVENT ELECTRIC SHOCK, MATCH WIDE BLADE PLUG TO WIDE SLOT FULLY INSERTED.



The lightning flash with arrowhead symbol in a triangle indicates the presence of uninsulated dangerous voltage within the product enclosure that may be of sufficient magnitude to constitute a risk of electric shock.

CAUTION

**RISK OF ELECTRIC SHOCK
DO NOT OPEN**

WARNING: To reduce the risk of electric shock, do not remove cover (or back). No user serviceable parts inside. Refer servicing to qualified service personnel.



The exclamation mark within the triangle alerts users to the presence of important operating and maintenance (servicing) instructions for the appliance.

The appliance should not be exposed to water and no object filled with liquid such as a vase should be placed on the unit.

Important Information

If a television is not positioned in a sufficiently stable location, it can be potentially hazardous if it falls. Many injuries, particularly to children, can be avoided by taking simple precautions such as:

- Using cabinets or stands recommended by the manufacturer of the television.
- Only using furniture that can safely support the television.
- Ensuring the television is not overhanging the edge of the supporting furniture.
- No placing the television on tall furniture (for example, cupboards or bookcases) without anchoring both the furniture and the television to a suitable support.
- Not standing the televisions on cloth or other materials placed between the television and supporting furniture.
- Educating children about the dangers of climbing on furniture to reach the television or its controls.
- Figures and illustrations in this user manual are provided for reference only and may differ from actual product appearance. Product design & specification may be changed without notice.

Safety Instruction

1. **Read Instructions** - All the safety and operating instructions should be read before operating.
2. **Retain Instructions** - The safety and operating instructions should be retained for future reference.
3. **Warnings** - All warnings on the appliance and in the operating instructions should be adhered to.
4. **Follow Instructions** - All operating instructions should be followed.
5. **Earthing Connection** - The TV shall be connected to a MAINS socket outlet with a protective earthing connection.
6. **Water and Moisture** - The appliance should not be used near water.
7. **Cart and Stands** - The appliance should only be used with a cart or stand that is recommended by the manufacturer.
8. **Wall or Ceiling Mounting** - The appliance should be mounted to a wall or ceiling only as recommended by the manufacturer.
9. **Ventilation** - The appliance should be well situated so that its location or position does not interfere with its proper ventilation.
10. **Heat** - This appliance should be placed away from heat sources such as radiators, heat registers and stoves.
11. **Power Sources** - The appliance should only be connected to a power supply as described in the operating instructions as marked on the appliance.
12. **Power Cord Protection** - Power supply cord should be routed so that it is not likely to be walked on, pinched by item placed upon it against the cord and its end.
13. **Cleaning** - The appliance should be cleaned only as recommended by the manufacturer.
14. **Power Lines** - An outdoor antenna should be located away from power lines.
15. **Outdoor Antenna Grounding** - If an outside antenna is connected to the receiver, the antenna system must be grounded so as to provide against voltages and built-up static charges.
16. **Non-use Periods** - The mains plug is used as disconnect device, the disconnect device shall remain readily operable. The power cord of the appliance should be unplugged from the outlet when left unused for a long period of time.
17. **Conditions Requiring Service** - The appliance should be serviced by qualified service personnel when:
 - The power-supply cord or the plug has been damaged.
 - Objects have fallen on or liquid has been spilled into the appliance.



Safety Instruction

- The appliance has been exposed to rain.
- The appliance does not appear to operate normally or exhibits a marked change in performance.

18. This appliance should not be exposed to water and no objects filled with liquids such as a vase should be placed on the unit.

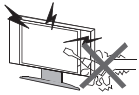

WARNING
High voltages are used in the operation of this product. Do not remove the back cover of the cabinet. Refer servicing to qualified service personnel.

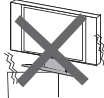

CAUTION
Do not place the main unit on an unstable cart stand, shelf or table.

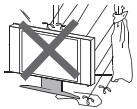

WARNING
To prevent fire or electrical shock hazard, do not expose the main unit to rain or moisture.

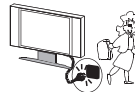

CAUTION
When the product is not used for an extended period of time, it is advisable to disconnect the AC power cord from the AC outlet.



WARNING
Do not drop or push objects into the television cabinet slots or openings. Never spill any kind of liquid on the television receiver.



CAUTION
The panel used in this product is made of glass. It can break when the product is dropped or applied with force.

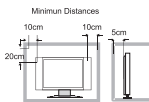

CAUTION
If the television is to be built into a compartment or similarly enclosed space the minimum distance must be maintained. Heat build up can reduce the service life of your television, and can also be dangerous.

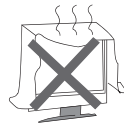

CAUTION
Avoid exposing the main unit to direct sunlight and other sources of heat. Do not position television receiver directly on other products which give off heat. E.g. video cassette players, audio amplifiers. Do not block the ventilation holes in the back cover. Ventilation is essential to prevent electrical failure. Do not squash power supply cord under the main unit.



CAUTION
Never stand or lean on product or its stand or push suddenly. Always pay special attention when children are near product to avoid harm.



Remote Control

Model No.: QT185



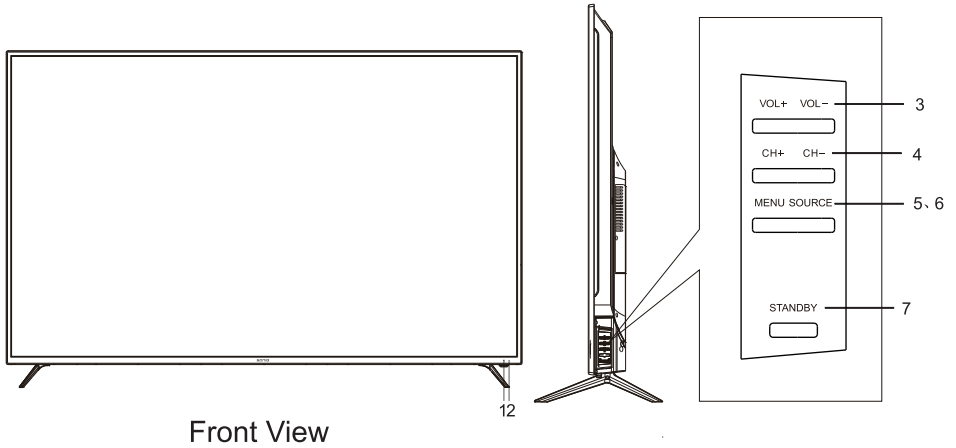

Front View

1		Remote Control Sensor Window	Receives signal from Remote Control. Do not put any objects in front of the window to hinder the reception of signal.
2		Power Indicator	Flashes red when the unit is powered on; Lights up red when the unit is in standby mode.
3		VOL +/-	Press VOL- to decrease volume, or VOL+ to increase. At the OSD menu, press these buttons to move the selection focus left and right to change settings.
4		CH +/-	Press these buttons to sequentially select channels. When the OSD menu is on, press these buttons to move the selection focus up or down to change settings.
5		MENU	Press this button to display the OSD menu. When the OSD menu is on, press this button to exit the menu.
6		SOURCE	Press to display all available input signal sources. Press to cycle through various sources.
7		STANDBY	Press this button to turn the unit on when it is in standby mode. Press this button once more to put it to standby mode.

Note:

Please use the above instructions according to the actual keys showed on TV.

Connection and Setup

Terminals on TV

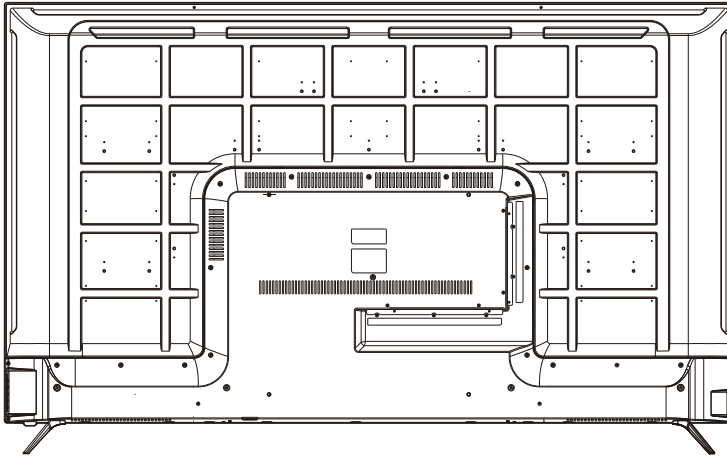

Back View

	Icon	Name	Description
1		SERVICE	For after-sales service.
2		ETHERNET	Connect the RJ45 Interface Ethernet.
3		HDMI	Connect to HDMI signal.
4		ANT IN	Connect to External Antenna.
5		Digital Audio Out (OPTICAL)	Connect to Digital Audio Amplifier OPTICAL Input.
6		EARPHONE OUT	Connect to external headphones.

Note:

Above listed is the universal version of SONIQ TV. Some terminals may not contained in some models.

CAST MODE

When you turn on the SONIQ TV for the first time, the default mode is Cast Mode.

Follow the bellow steps to launch Cast Mode.

NOTE: The application interface may be subject to change as the Google app updating, please obey the actual on-screen images.

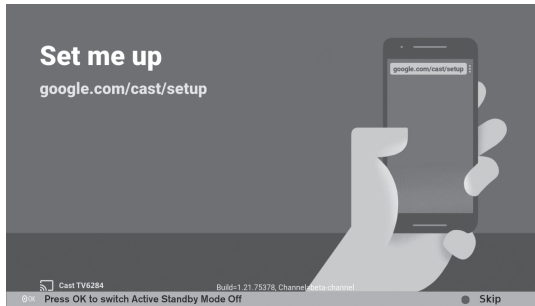

Or if you don't want to enter Cast Mode, press the BLUE button on the remote control (and use the Right button to move the cursor to "YES" in pop-up dialogue) to skip Cast Mode. In future, to access Cast Mode, directly Press the Cast button on the remote control or press the Source button to choose Cast Mode.

1.DOWNLOAD THE GOOGLE HOME APP

Use your mobile device as the best remote to cast your favorite shows, movies, music, sports, games, and more to the big screen.

Just open the mobile apps you already know and love to quickly access your TV shows and playlists. No new log-ins or downloads required.

Scan below QR codes to download Google Home quickly :



For iOS



For Android

CAST MODE

If Google Home app can't be downloaded directly via the QR code due to the download address has been changed. Please download it at Google Play Store or Apple App Store.

- Android phone or tablet (Android 4.1 and higher)

For a list of supported devices, see [Google Play™ supported devices article](#).



- iOS phone or tablet (iOS 8.0 and higher)



Availability subjects to change without notice.

Features

DISCOVER NEW ENTERTAINMENT WITH THE GOOGLE HOME APP

The Google Home app lets you easily browse featured content and search for your favorite movies and TV shows. Plus, it's your central place for finding the latest on new apps and offers.

ENJOY HIGH-QUALITY VIDEO, POWERED BY THE CLOUD

Google Home uses the cloud to stream content to your TV, so you get HD video (and Ultra High Definition video using select devices and apps) with high-quality sound.

MULTI-TASK WITHOUT INTERRUPTION

Send texts and accept calls while casting without disrupting what's playing on the TV or draining your phone's battery.

2. PAIR YOUR MOBILE DEVICE WITH SONIQ DISPLAY

- (1). Turn on the SONIQ Display by pressing the Power button on the side of the TV or by pressing the Power button on the Remote Control.
- (2). The TV can connect with wireless Wi-Fi network (use your phone/tablet and follow below steps to connect) or wired network (use a RJ45 Ethernet cable to connect). Make sure your phone or tablet is connected to the same network you will use with your Chromecast built-in TV.
- (3). Launch the Google Home app on your device. But first, tap “Accept” to agree to the Terms of Service and Privacy Policy of Google Home.
NOTE: For iOS devices, Google Home app will ask you to turn on Bluetooth.

Highly recommended: Turn on Bluetooth to help improve the setup process. You can swipe up from the bottom and turn on Bluetooth or tap SETTINGS to turn on Bluetooth, then return to the Google Home app.

If you don't want to use Bluetooth for set up, use Wi-Fi hotspot to setup: Tap your iPhone's Home button > Go to your iOS Settings > WLAN Connect to the Wi-Fi network that matches your Chromecast built-in device. Look for something like CastTVXXXX.

Navigate back to the Google Home app. Your device should now be detected. Tap CONTINUE.

- (4). Hold your device close to the SONIQ TV and look for the code on the bottom right corner of your TV. And tap “I SEE THE CODE” to continue.

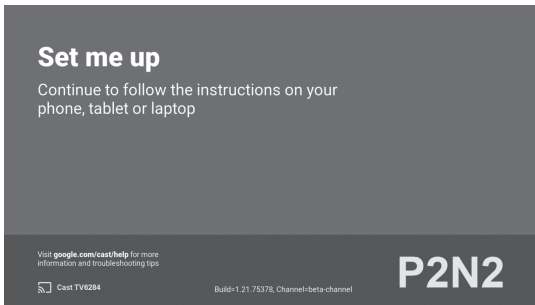

SONIQ Display

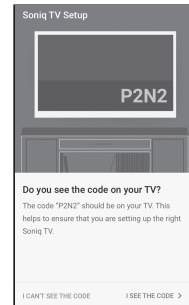

Your Device

- (5). Use the phone to select your region and name your SONIQ Display. And tap “CONTINUE” to proceed. If guest mode is enabled, it will allow compatible devices in the same room to cast without being on your Wi-Fi network.

CAST MODE

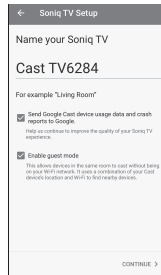

- (6).The phone begins to search for a wireless network to connect to. Choose the Wi-Fi network you want to connect your Chromecast built-in TV to and enter your password. Tap “CONTINUE” to next step.



If your TV connected with a wired network via the Ethernet jack, this step won't exist.

- (7).The First-Time setup is complete. Contents on the cast-enabled apps can be casted on the SONIQ display by pressing the Cast icon.

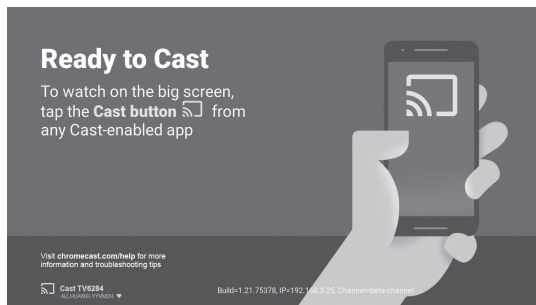

SONIQ Display

3.LAUNCH THE GOOGLE HOME APP

The Google Home app lets you find your favorite content, across multiple cast-enabled apps in one simply aggregated screen, making it easy to discover and enjoy videos, games, music and more.

Navigate the Google Home app

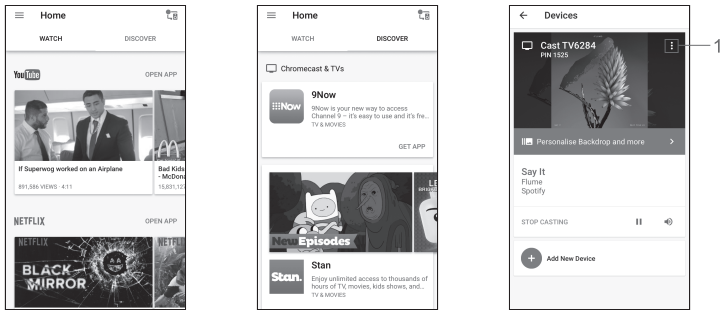

The contents in the downloaded cast-enabled apps will display under the WATCH menu.

Find more cast-enabled apps under DISCOVERY menu.

Your connected SONIQ TV will display in the DEVICES menu. Tap “STOP CASTING” to stop casting.

1.Tap the  icon to reveal Settings Menu.

- (1).Settings: Check the device information, and you can rename your SONIQ TV in this menu.
- (2).Backdrop setting: tap to set the backdrop to show on your SONIQ display.
- (3).Guest Mode: to turn On or Off guest mode.

2.Tap the top left corner  button to reveal a list of content to get more Google Home information.

Note: The images shown here are for illustrative purposes only and may be subject to change. The actual on-screen image and text may vary, depending on the phone model.

CAST MODE

4. PICK SOMETHING TO WATCH

After you get the hang of using the Google Home app, it's time for you pick and choose something to watch.





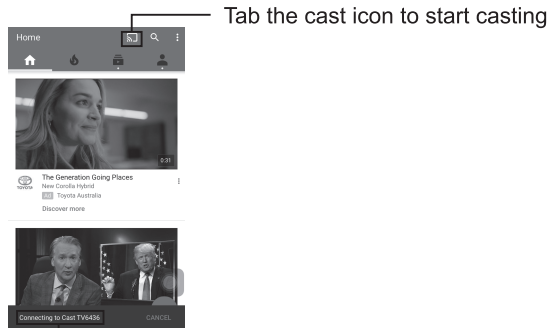

1. Find films, TV shows, and more with the Cast-enabled apps, open an app and tap the Cast  icon to mirror your mobile device.

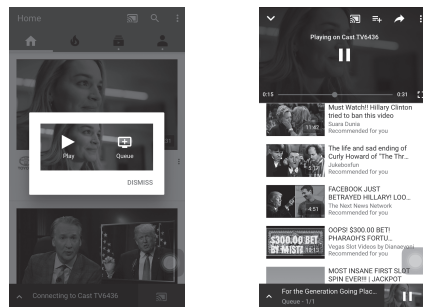

Select a TV to watch videos on

2. Depending on which video app you pick, the content will be organized into several collections. Scroll up and down through the list to pick what you want to watch or search for a title by tapping the search icon.
3. Select a source and tap the play button.



4. A) Tap on the Cast  icon again and select “Disconnect” to stop casting.
- B) Tap the  icon to add the video to Queue and/or Playlist.
- C) Tap  icon to set the video to Play next, or to Add to Queue, or to Add to Watch Later, or to Add to Playlist.
- D) Your title begins playing on your display.
- E) Tap the title on the bottom row to display the QUEUE.

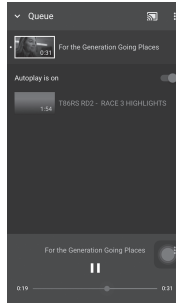

Note: The images shown here are for illustrative purposes only and may be subject to change. The actual on-screen image and text may vary, depending on the app.

CAST MODE

4. PICK SOMETHING TO LISTEN TO

1. Open a cast-enabled music app on your mobile device, tap the Cast icon to cast it to the SONIQ display.

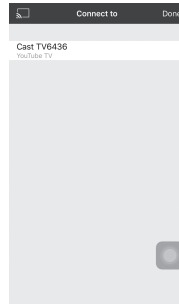

2. You can pick your content from the list or search for a title by tapping the search icon.
3. Tap on the content you want to listen to and the music begins to play on your SONIQ TV.

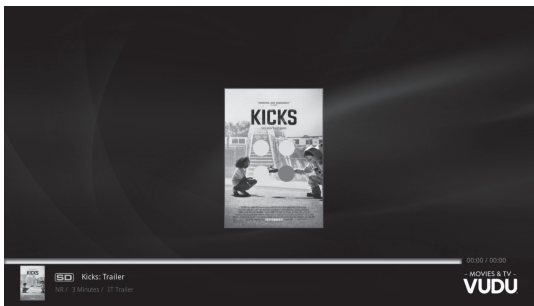

SONIQ Display

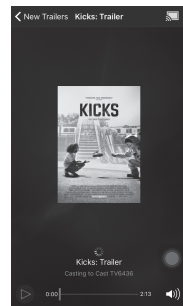

Your Device

4. Depending on which music app you pick.
 - A) Tap on the Cast icon again and select "Disconnect" to stop casting.
 - B) Select "Add Playlist" to set up New Playlist and add the track to your library.
 - C) Tap the Home button to see your Music Playlist.

Note: The images shown here are for illustrative purposes only and may be subject to change. The actual on-screen image and text may vary, depending on the app.

4. GAME ON. GAME BIG.

Use Google Cast to turn your SONIQ TV into a dancefloor, racetrack, and more. Friends can use their own phones as controllers, all while watching the action live on the big screen.

1. Find popular games from the Google Home app, pick a game app and tap the Cast  icon to mirror your mobile device.

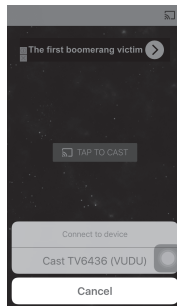

2. Use your mobile phone as a controller and begin to play the game in big screen.

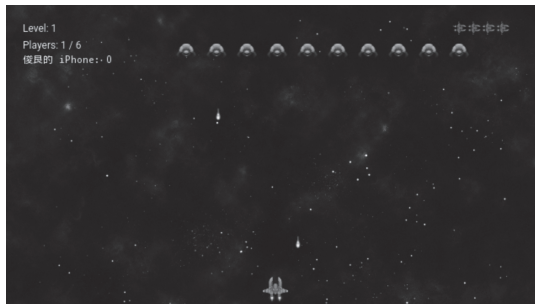

3. Tap the Cast icon on your mobile phone again to select "Disconnect" to stop casting.

Note: The images shown here are for illustrative purposes only and may be subject to change. The actual on-screen image and text may vary, depending on the app.

CAST MODE

4. BROWSE WEBSITE

Mirror any website on your laptop's Chrome browser. Supports Mac, Windows PC or Chromebook. Meanwhile you can carry out other tasks on your PC without disrupting what's playing on the TV.

1. Connect your laptop to the same LAN (Local Area Network) as your SONIQ TV. Open your Google Chrome Browser.
2. Click "Cast" icon and select a TV to cast to.
3. The website on your laptop starts to cast to the SONIQ display.

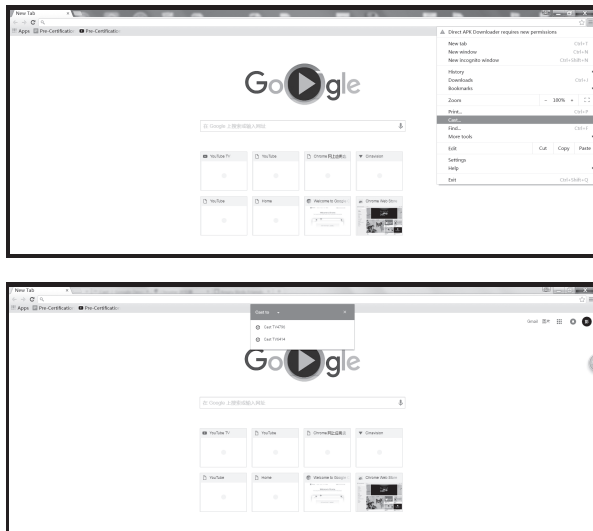

5. USE YOUR MOBILE DEVICE / PC AS THE BEST REMOTE CONTROL

Programme Selection :

Depending on which app you pick, use your mobile device/PC as a remote control to freely switch any on-line programmes in cast-enabled apps for your preference.

Volume Adjustment :

Just press the Volume+/- buttons on your mobile devices to adjust the volume of your SONIQ TV. You can also use the TV remote control to change the volume.

OSD Menu Operation

Before operating OSD(On Screen Display) menu, please switch to full screen playback.

Press Menu button on the remote control to show the available menus on the bottom of the screen.

CHANNEL MENU

Check your antenna connection and press Source button on the remote control to select DTV mode first.

Press Menu button to access CHANNEL menu. From this menu you can access the following options: Auto Tuning, Manual Tuning, Program Edit.

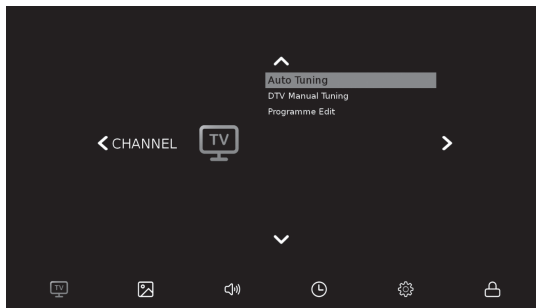

Auto Tuning

Automatically finds all channels available through antenna or cable inputs, and stores them in memory on the channel list.

Run this function if you change your residence or move the TV.

1. Use Up/Down button to highlight Auto Tuning, and press OK button to proceed.
2. Press navigation keys to select Time Zone.
3. Press OK button to start Auto Channel Tuning.

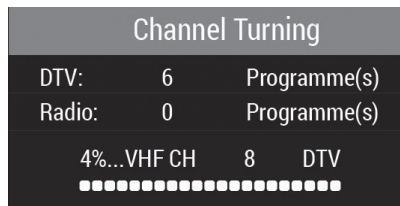
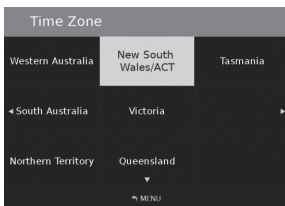

OSD MENU

Manual Tuning

When selecting DTV input signal in Manual Tuning, you can view the on-screen signal strength monitor to see the quality of the signal being received.

1. Press Up/Down buttons to highlight Manual Tuning, then press OK to enter sub-menu.
2. Press Left/Right buttons to select channel and press OK button to start searching.

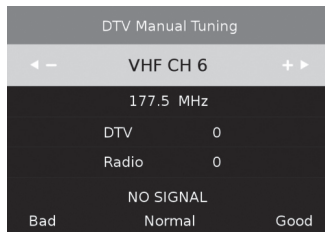

Program Edit

Press Up and Down button to select Program Edit, then to press OK to enter.



Color Function buttons

1. Press RED button on the remote control to delete the selected channel from the channel list.
2. Press the BLUE button to skip a channel when using CH +/- buttons.
3. Press the FAV button to add a channel to your favorite List, press it again to remove the channel from the Favorite List.

PICTURE MENU

The Picture menu offers options to enhance and refine the picture displayed on your TV based on ambient room light and personal preferences. Press Menu button, then press Left and Right button to select PICTURE MENU.



Picture Mode: Go a long way to giving you the best possible image.

1. Use Up/Down button to highlight Picture Mode and press OK to enter sub-menu.
2. Press Left and Right buttons to adjust the picture mode by Standard, Mild, User and Dynamic.

Standard - This mode offers a better color balance when used in an average lit room.

Mild - This mode typically produces an excellent image and makes your eyes feel comfortable.

Dynamic - This mode is for when your room is brightly lit or during the day.
User mode - Contrast, Brightness, Color and Sharpness can be manually adjusted under this mode.

Contrast: Increases or decreases the gradient of the video signal. You may use Contrast when the bright part of the picture is saturated.

Brightness: Adjusts the base level of the signal in the picture. You may use Brightness when the dark part of the picture is saturated.

Color: Adjusts intensity of all colors.

Sharpness: Adjusts the level of crispness in the edges between the light and dark areas of the picture. The lower the level, the softer the image.

3. Press Menu button to return to the main menu.

OSD MENU

Color Temperature: Adjust picture color temperature.

Use Up/Down button to highlight Color Temperature and press OK to enter sub-menu.

Press Left and Right buttons to adjust the mode between Standard(balanced), Warm(reddish),User(adjustable) and Cool(bluish).

Aspect Ratio: Adjust picture size.

1. Use Up/Down button to highlight Aspect Ratio and press OK to enter sub-menu.
2. Press Up and Down button to select Full, 4:3 or Auto.

Energy Saving: Adjust brightness of TV's screen.

Press Up/Down to highlight Energy Saving and Press OK button to switch it between Standard, High and No. It can reduce the TV's power consumption by lowering the backlight level.

Noise Reduction: Remove irregular and erratic pixels for a clearer image.

1. Use Up/Down buttons to highlight Color Temperature and press OK to enter sub-menu.
2. Press Up and Down buttons to select Off, Low, Middle or High.

Screen Mode: Available under HDMI signal to adjust the picture ratio.

Use Up/Down buttons to choose Screen Mode. Press OK to switch PC(100%) or Video(97%).

Color Space: Available under HDMI signal to adjust picture color.

Run this setting when the picture color is abnormal.

Press OK to switch it among Auto, RGB Full or RGB Limited until the picture color can normally display.

SOUND MENU

The Sound menu offers options to enhance and refine the sound setting on your TV based on personal preferences.

Press Menu button to display the main menu. Press Left/Right buttons to access SOUND MENU.

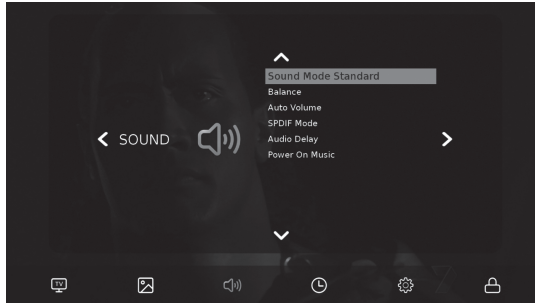

Sound Mode: Adjust for optimum sound quality.

Highlight Sound Mode and press OK to enter. Press Left/Right buttons to pick Sound Mode among Standard, Music, Movie, Sport, User Mode.

You can adjust the value of Bass and Treble under User Mode.

Treble: Adjusts the high frequency intensity setting.

Bass: Adjusts the low frequency intensity setting.

Balance: Adjust the left/right sound of speaker to suit your taste and room situations.

1. Press Up/Down to highlight Balance, and press OK to enter sub-menu.
2. Press Left/Right buttons to adjust the value.

Auto Volume: Set the digital audio out setting.

Press Up/Down to highlight Auto Volume, and press OK button to switch it On or Off.

SPDIF Mode: Set optical audio output.

Press Up/Down to highlight SPDIF Mode, and press OK button to adjust it among Bistream, Off or PCM.

PCM (Pulse-code modulation)- Modifies the incoming audio signal and outputs in 2-channel stereo sound.

Bistream- Does not make any changes to the incoming signal and passes through the original Dolby sound output.

Off- Turns off the Optical audio signal.

OSD MENU

Audio Delay: Fix audio and lip sync issues.

1. Press Up/Down to highlight Audio Delay, press OK to enter.
2. Press Up/Down buttons to select SPDIF Delay or Speaker Delay. Speaker Delay is to adjust the setting to fix any lip sync issues; SPDIF Delay is to adjust the setting to fix any lip sync issues when the TV is connected to an external amplifier.
3. Press Left/Right buttons to adjust the delay time.

Power On Music: Set music on or off when turning on TV.

Press Up/Down to highlight Power On Music, and press OK button to switch it On or Off.

TIME MENU

To access Time menu, press the MENU button, then to use Left/Right buttons to select TIME menu.

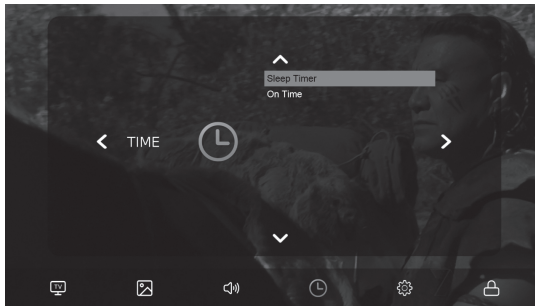

Sleep Timer:

Set the timer in minutes for when you would like the TV to turn off.

1. Press Up/Down buttons to select Sleep Timer and Press OK to enter.
2. Press Up/Down button to set the time.

Time Zone:

Select your time zone.

1. Press Up/Down buttons to select Time Zone and Press OK to enter.
2. Press Navigation keys to select Time Zone.

OPTION MENU

The Option menu offers options to set the TV operating environment. To access Option menu, press the MENU button, then to use Left/Right buttons to select OPTION menu.

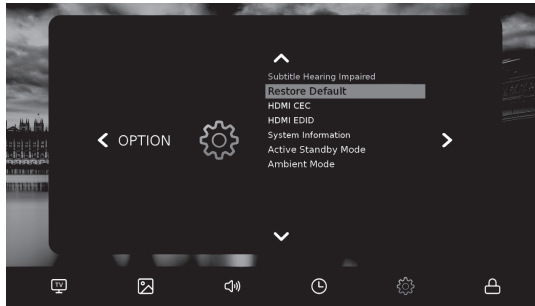

Subtitle Hearing Impaired:

Hearing impaired subtitles translate all the sound in the show into words. (Only available in DTV mode and must be supported by viewing program) Press Up/Down buttons to highlight this item, and press OK to switch it On or Off.

Restore Default: Reset to factory default settings.

Press Up/Down buttons to highlight Restore Default, and press OK. There will be a dialogue box to remind Yes or No.

HDMI CEC:

Press Up/Down buttons to select HDMI CEC and Press OK to enter.

1. HDMI CEC On/Off: Turn On CEC to activate Auto Standby and ARC settings.
2. Auto Standby On/Off: When turned On, the CEC-enabled external device will go into standby when the TV is placed in standby.
3. ARC On/Off: (Only available under HDMI 2) When turned On, send audio back to the ARC-enabled external audio device.
4. Auto Power On: Press Left/Right buttons to Auto Power, and press Up/Down Buttons to select On or Off. Turn on to activate the TV on when switch on the external DVD.

HDMI EDID: Deal with picture problem when connecting a HDMI device.

Press Up/Down buttons to select HDMI EDID and press OK to switch it between EDID1.4 (supports 4K@30Hz) or EDID 2.0 (supports 4K@60Hz) until your device can work properly.

OSD MENU

System Information:

Press Up/Down buttons to highlight System Information, and press OK to see the system Information.

Active Standby Mode:

Press Up/Down buttons to highlight Active Standby Mode, and press OK to switch it On or Off. Switch this setting on, the television can be turned on by pressing the Cast icon on your mobile device when it is in Standby mode.

Ambient Mode:

Press Up/Down buttons to highlight Ambient Mode, and press OK to switch it On or Off. If it is turned on, the television will automatically switch to cast mode when pressing Power button and the screen's light becomes darker.

LOCK MENU

Press the MENU button, then to use Left/Right buttons to select LOCK menu. A password is required to gain access to this menu. Press OK button and input the factory default password "0000" using the number buttons on the remote control.

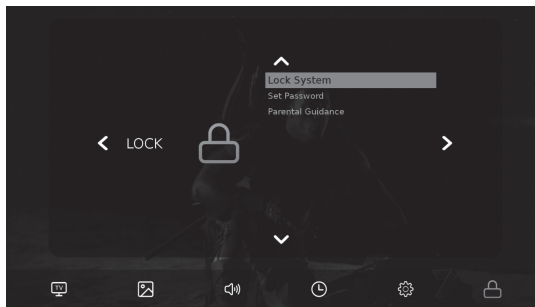

Lock System:

Enables or disables the blocking scheme you set up previously.

Set Password:

Set personal password. Press Up/Down buttons to highlight Set Password and press OK button to enter.

Parental Guidance:

Parents can set age limit level by this function (System Lock should be switched On). Press Up and Down to select Parental Lock, then press OK to enter the setting.

EPG (Electronic Program Guide)

EPG TV Guide (for DTV mode only)

EPG stands for Electronic Program Guide. It is supplied by the program providers and offers information about the programs to be broadcast.

1. Press EPG button on the remote control to display the EPG interface.
2. Press Left/Right buttons repeatedly to sort the available channels by scheduled time or Channel name.
3. Press the Up/Down buttons to select a different channel/program in the list and press OK to activate the channel.

Color Function buttons

Press RED Button to display the program index.

Press GREEN Button to display full program information.

Press YELLOW Button to schedule the program.

Press BLUE Button to set a reminder for the selected program.

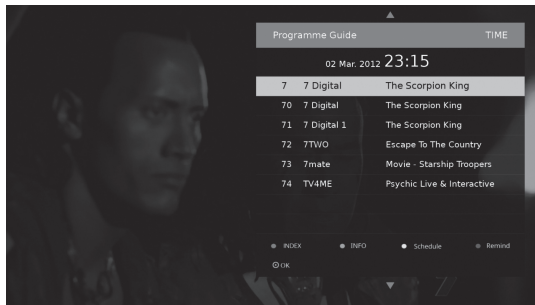

If you experience any problems with your TV, check the list below and take any necessary steps before calling for service. If none of the solutions help you solve the problem, turn the power off and contact the after sales support line for advice.

Before calling a service center, attempt the following steps to diagnose the problem.

1. There is no power.

Ensure the power plug is securely inserted into the unit and wall outlet.

2. There is no picture or sound.

Try a different input source to check whether the source is at fault.

Check for mis-connection of cables or for wrong input source.

3. There are spots on the screen.

Your unit is being affected by interference from automobiles, trains, high-voltage transmission lines, neon signs or another sources of interference. Try redirecting or relocating your antenna to reduce the affects of the interference.

4. Degraded colors or tints.

Check whether all the picture adjustments have been properly performed.

5. Improper Screen position or size.

Try selecting a different aspect ratio by pressing the <ASPECT> Button on the remote control.

6. The image appears distorted.

Ensure the display aspect ratio is correctly set to suit the program source.

7. The image appears too bright, and there is a loss of definition in the brightest areas of the image.

Reduce the contrast settings.

8. The image appears too washed out, or the darkest areas of the image appear too bright.

Reduce the brightness level till the black areas of the picture appear as black.

9. Remote Control does not function properly.

Check for incorrect battery orientation.

Check for dead batteries.

Check your distance and angle from display.

Check whether remote control is pointing at sensor window;

Check for any obstacle between the Remote Control and Remote Control sensor.

Check that the Remote Control sensor window is not under strong fluorescent lighting.

Check for any devices (PC or personal digital assistant, PDA) nearby that transmit infrared signal which may cause interference to signal transmission between the Remote Control and the unit.

Turn off the infrared function of these devices.

10. There is no picture or sound, just noise.

Make sure the antenna cable is properly connected.

Change channels to confirm if the symptom is still present.

11. Picture is not clear.

Make sure the antenna cable is properly connected.

Change channels to confirm if the symptom is still present.

12. No sound.

Check whether you have selected the Mute function.

Make sure the volume is not set to minimum.

Antenna

1. The picture is not sharp.

The reception may be weak.

Change channels to confirm if the symptom is still present.

Make sure the outside antenna is not disconnected.

Make sure the antenna is facing the right direction.

2. The picture is doubled or tripled.

Make sure the antenna is facing the right direction.

Picture ghosting is caused by reflections from buildings, large metal structures and mountains.

Carefully realign your antenna to minimize the ghost images. Ultimately a higher quality antenna professionally installed may be necessary to reduce the ghosting.

3. The picture is spotted.

There may be interference from automobiles, trains, high voltage lines, neon lights, etc.

There may be interference between the antenna cable and power cable, try positioning them further apart.

4. There are stripes on the screen or colors fade.

Is the television receiving interference from other devices? Transmission antennas of radio broadcasting stations and transmission antennas of amateur radios and cellular phones may also cause interference. Use the television as far away as possible from devices that may cause possible interference.

Specifications

Supports HDMI-PC Input Signal

Your SONIQ TV unit can also be used as a HDMI-PC monitor, which supports below modes:

HDMI/DVI-PC mode INPUT SPEC				
HDMI/1/2/3 input				
INPUT FORMAT	Resolution	Horizontal Frequency (KHz)	Vertical Frequency (Hz)	Standard
	640 X 480	31.5	60	VGA
	640 X 480	37.861	72.809	VESA
	640 X 480	37.5	75	VESA
	720 X 400	31.5	70	VGA-T
	800 X 600	37.9	60	VESA Guidelines
	800 X 600	48.077	72.19	VESA
	800 X 600	46.9	75	VESA
	832 X 624	49.7	75	Mac
	1024 X 768	48.4	60	VESA Guidelines
	1024 X 768	60	75	VESA
	1125 X 870	68.68	75	Mac
	1280 X 800	47.8	59.8
	1280 X 960	60.0	60	VESA
	1280 X 1024	63.595	60	VESA
	1440 X 900	55.9	59.9	VESA
	1680 X 1050	65.3	60
	1920 X 1080	67.5	60	VESA
	3840 X 2160	67.5	30	

Power Source	~200-240V AC, 50Hz	
Power Consumption	180W	
Video Format Supporting	HDMI	480p, 576p, 720p (50/60Hz), 1080i (50/60Hz), 1080p (23.97/24/25/29.97/50/59.94/60Hz) 3840x2160(24/25/30/50/60Hz)
Digital TV	Programme Coverage	VHF 06 to 12 UHF 27 to 69
	Video Decode	1080i ,720p ,576p,576i
	Audio	MPEG,AC3
Panel Spec	Display Area HxV(mm)	1428.48(H) x 803.52(V)
	Panel Native Resolution	3840 x 2160 pixels
	Brightness	250 cd/m ²
	Contrast Ratio	2500:1 Typ
	Color Depth	10-bit(D), 1.07 Billion colors
Input/Output	ANT IN	ANT IN x 1
	HDMI IN	HDMI x 3
	SERVICE	SERVICE x 1
	Digital Audio Out (Optical)	Digital Audio Optical Out x1
	LAN	LAN x 1
	Earphone out	Earphone x 1
Audio Power	8W + 8W	
Unit Dimension with Stand	1461.0(L) x 290.5(W) x 904.2(H)mm	
Wireless LAN Specification	Standard	802.11a/b/g/n
	Frequency Band	2.4~2.4835 GHz ISM Band, 5.150~5.825 GHz ISM Band
	Output Power (max)	2.4~2.4835 GHz 19dbm , 5.150~5.725 GHz 16.5dbm, 5.725~5.825 GHz 15dbm

We reserve the right of final interpretation.

SONIQ

HOTLINE

AUSTRALIA :1300 765 663
NEW ZEALAND :0800 100 236

MD161025-01
Printed in China

www.soniq.com